

OIL RECOVERY PUMPING SOLUTIONS

LOBEPRO BENEFITS:

1. Perfect for handling mixtures of air, water, and thick oily sludge.
2. Low-shear pumping, will not homogenize or emulsify the liquid, resulting in more efficient oil/water separation.
3. Reversible flow without piping changes for loading/unloading operation (AC motor & hydraulic drives)

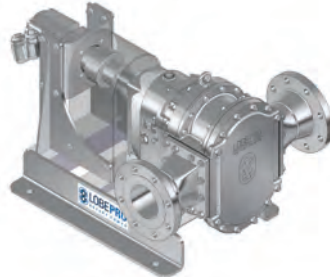

Hydraulic Drive

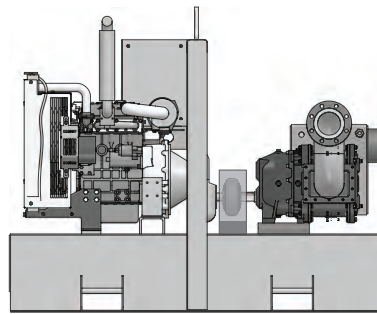

Diesel Drive w/Integral Fuel Tank

LOBEPRO PROPERTIES:

- Run-Dry ability
- Self-priming
- Replace wear parts in place without disturbing piping
- 0-2600 GPM, pressures to 150 psi.
- Made in USA
- Handles soft solids to 2.5 inches (seaweed etc.)
- Spare parts ship in 48 hours or free

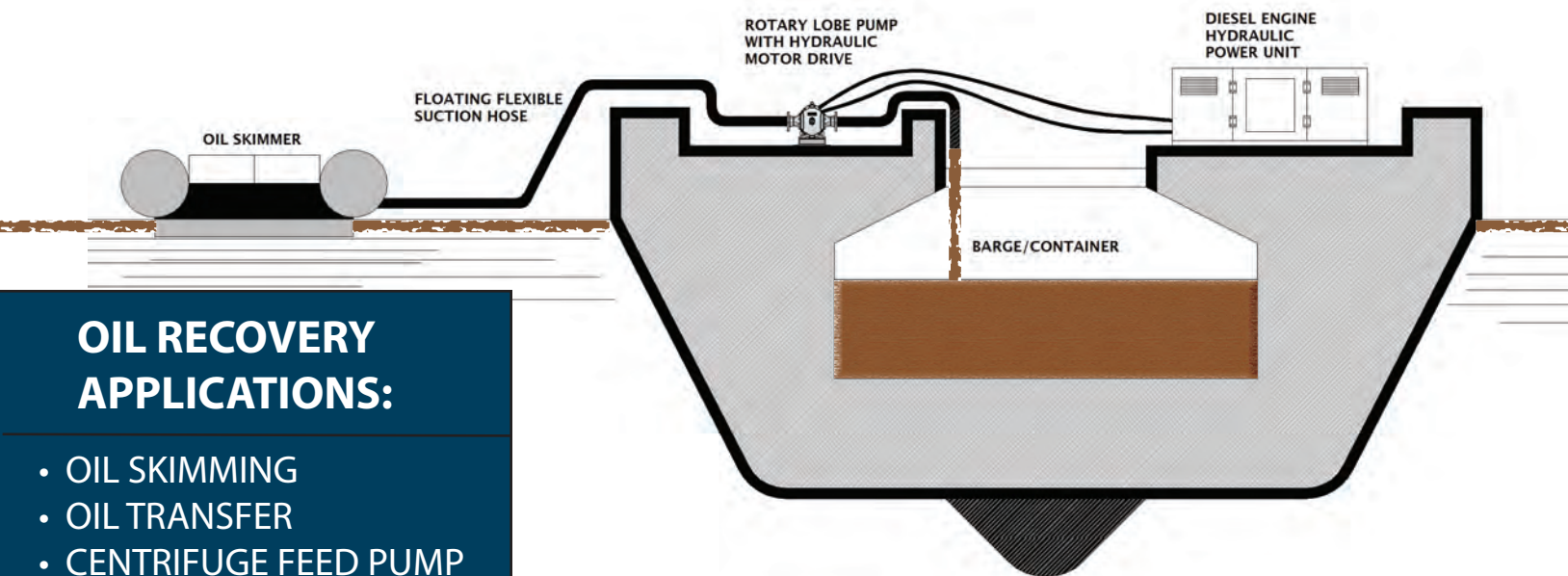

OIL RECOVERY APPLICATIONS:

- OIL SKIMMING
- OIL TRANSFER
- CENTRIFUGE FEED PUMP
- DECANTING FEED PUMP
- LOADING/UNLOADING

Other Arrangements:

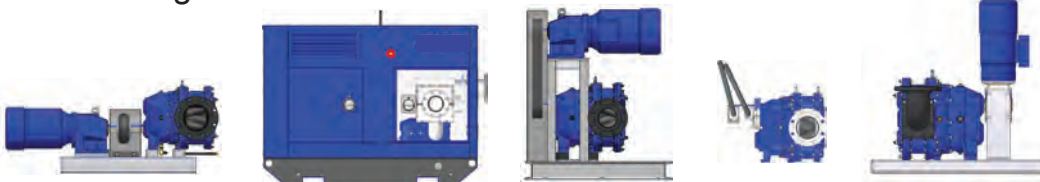

LobePro Inc.
 (ph) 912-466-0304
 (fax) 912-466-0086
 info@lobepro.com
 www.lobepro.com